

# Tiltrotator EC02

## For 3,300–7,700 lbs excavators (1,5–3,5 metric ton)

One of the market's smallest tiltrotators, this is designed for machines weighing up to 7,700 lbs. With a base weight of 170 lbs, the EC02 has minimal impact on stability while delivering access and flexibility that only a tiltrotator can provide.

### Features:

- » Rotation  $\infty$
- »  $\pm 40^\circ$  tilt
- » Complies with European safety standards
- » A load-holding valve as standard equipment provides maximum safety

**Quick coupler:** We offer most types of couplers available on the market.

**Control system:** Choose between several different controls systems based on your machine's features. The EC02 can easily be fitted with engcon's DC2 proportional control system for outstanding variable high-precision control and remote support via exclusive smartphone app.

**Electrical system:** Standard 12V.

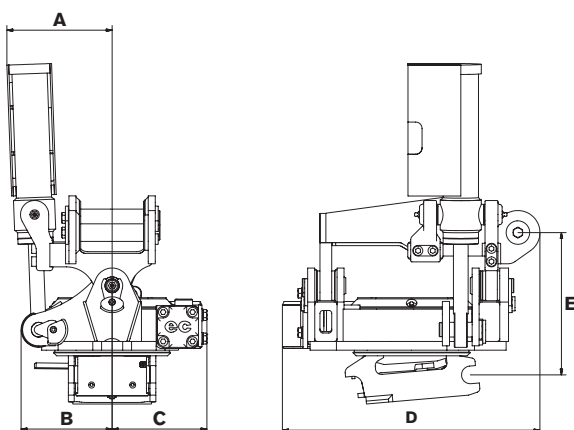

### Specifications

Model	EC02
Width A (inches)*:	7,1
Width B (inches)*:	6,1
Width C (inches)*:	6,3
Total length D (inches)*:	17,1
Construction height E (inches)*:	from 9,6
Weight (lbs)*:	170
Tilt range:	2x40°
Rec. hydraulic flow DC2 & SS10 (gpm):	6,6
Rec. hydraulic flow SS9 tilt/rotation (gpm):	1,8/5,3
Max hydraulic pressure (psi):	3,200
Standard mountings:	S30
Max bucket width rec. by engcon (inches):	35,4
Max torque (lbf):	14,751
Base machine weight min/max (lbs):	3,300–7,700

\* Standard attachment

**CHANGE THE WORLD OF DIGGING**

engcon North America Inc. | 2666 State Street, Hamden CT 06517  
 Phone +1 203 691 5920 | Email northamerica@engcon.com | Web engcon.com